

The Safety Benefits of FlexForm Sound™ LVT

Slip and Fall Protection

Milliken™



LVT SLIP & SAFETY GUIDE

When specifying Luxury Vinyl Tiles, it's important that the LVT doesn't just offer the desired aesthetic but is also engineered to meet stringent safety standards.

The majority of non-fatal injuries at work are caused by slips, trips or falls on the same level*, therefore safety considerations should be part of the specification process and the appropriate flooring selected for its intended environment.

Milliken's LVT complies with:

- Class 33 certification for heavy commercial use
- CE safety certifications for fire, static and slip

Our LVT collections are rigorously tested using the following methods:

- CE mark co-efficient of friction test - EN 13893
- Ramp Test - DIN 51130
- Pendulum Test - BS 7976

The better the slip resistance, the lower the risk of accident which gives you and your clients peace of mind.

29%

of non-fatal injuries at work are caused by slips, trips or falls on the same level.



LVT ORIGINAL COLLECTION / Heritage Wood HER218
Carpet — **COLOUR COMPOSITION** / Compound Magic,
CMP173 Slipware, CMP166/173 Slipware / Crayon CMP166 Crayon

*Health and Safety Executive 2019

SELECTING THE CORRECT FLOORING FOR DIFFERENT ENVIRONMENTS

Milliken's LVT offers the best slip rating required for commercial use. Our slip resistant LVT collections are perfect for the following environments:

- Office / tea break areas
- Schools / Student accommodations
- Restaurants / Bars
- Shops / Supermarkets / Department stores
- Public buildings
- Gyms
- Care homes / Nurseries / Animal care
- Hair salons
- Entrance lobbies (in conjunction with appropriate protective flooring to remove rain moisture)

Note: specialist floorings are needed for the following applications; where a safety floor is specified, wet rooms and professional kitchens.



OFFICE SPACES



LVT FIRST CALL / Open Shut OPS121-204 Cone
Carpet — DISSIDENT 2.0 / DST153-144 Boom Town



Bühler, London UK
LVT ORIGINAL COLLECTION / Polished Concrete POL13



TEA BREAK AREAS

Bühler, London UK
LVT ORIGINAL COLLECTION / Polished Concrete POL13

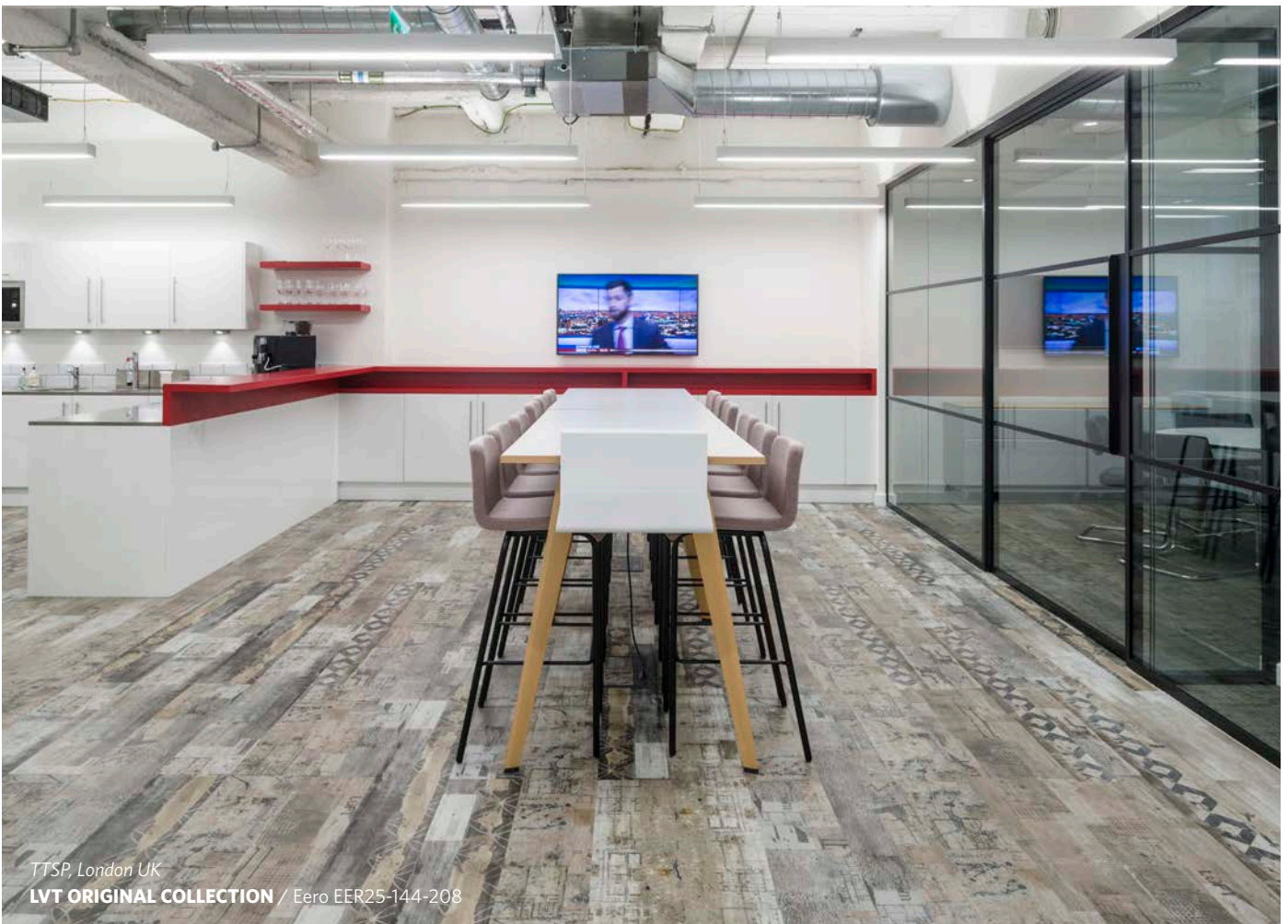

TTSP, London UK
LVT ORIGINAL COLLECTION / Ero EER25-144-208



PUBLIC SPACES

LVT FIRST CALL / Open-Shut OPS144 Scion
Carpet — **POISE** / POI153-138-180 Bliss



SCHOOLS

LVT FIRST CALL / Open-Shut OPS144 Scion
Carpet — **COLOUR COMPOSITION** / CMP172 Blend,
CMP144 Ash Glaze, CMP172-165 Chamois / Blend

SHOPS



LVT CHANGE AGENT / Earth Science, ESN174 Mineral / ESN98 Composition



HAIR & BEAUTY SALONS

LVT FIRST CALL / On-Point ONP176 Rootstock



CARE HOMES

LVT FIRST CALL / On-Point ONP76-144 Crown
CRAFTED SERIES / Woven Colour WOV259-83-37 Sage

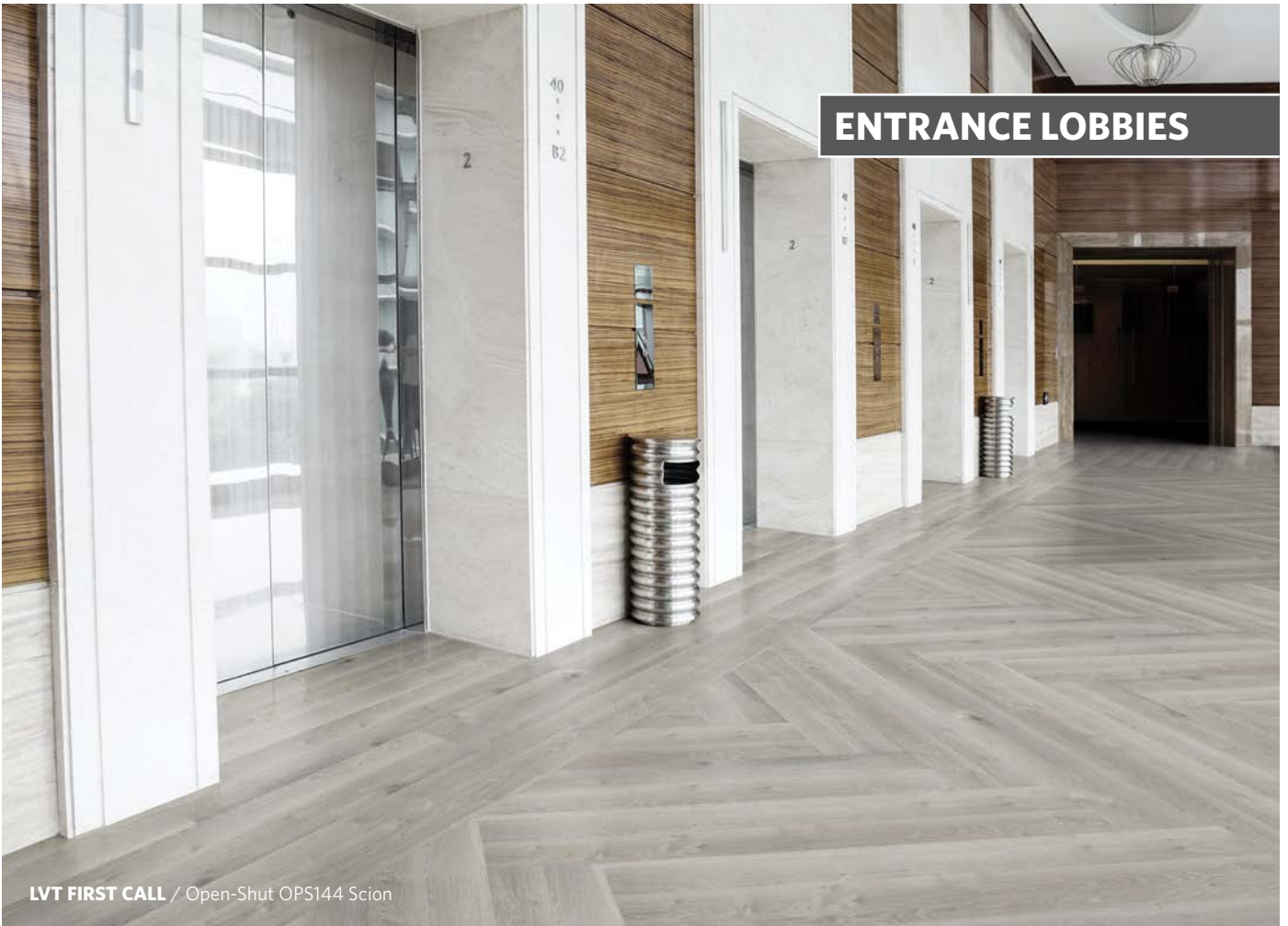

ENTRANCE LOBBIES

LVT FIRST CALL / Open-Shut OPS144 Scion



RESTAURANTS & BARS

LVT FIRST CALL / On-Point ONP208 Samara

SLIP RESISTANCE – TEST METHODS

Milliken's LVT not only complies with Class 33 certification for heavy commercial use, but also meets the CE safety certifications for fire, static and slip.

Our LVT collections are rigorously tested using the following methods:

A. CE mark co-efficient of friction test - EN 13893

How does the test work?

Weighted sliders are pulled across the dry LVT horizontally at a constant speed. The result is calculated by measuring the force required to move the slider and the weight of the slider.



B. Ramp Test - DIN 51130

How does the test work?

Humans walk over the LVT which has been contaminated with oil or water. The flooring is tilted at ever increasing angles of inclination. Ratings are given according to the angle at which a slip occurs.

The industry required standard as a minimum is R9/R10, with <6 registering as Unclassified.

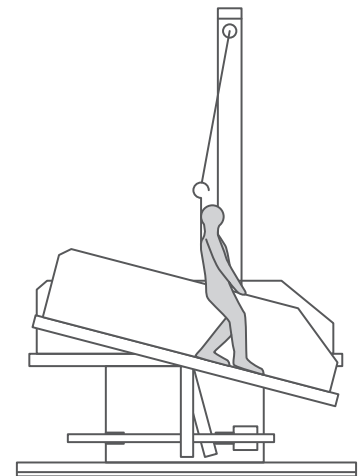

C. Pendulum Test - BS 7976

How does the test work?

A swinging arm fitted with a rubber slider is made to glide over a set distance of LVT flooring.

Pendulum Test Values (PTVs) are given according to the height lost on the overswing.

Each flooring sample is tested numerous times and in three different directions: 0°, 90° & 45°.

The flooring is tested as a dry surface and then as a wet surface, with both sets of PTVs recorded.

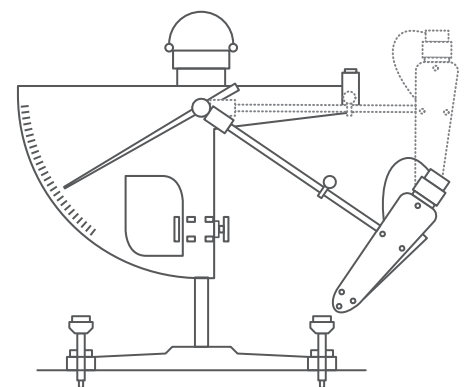

"The pendulum test... This is HSE's preferred method of testing":

https://www.hse.gov.uk/SLIPS/step/general/advanced/8E7F777B-3B84-49FE-A3D6-D0324E25A801/HSLCourseTemplate/28531/slidetype1_280757.htm
See also: <https://www.hse.gov.uk/pubns/geis2.pdf>

UKSRG (UK Slip Resistance Group) guidelines:

"...for unencumbered, reasonably active pedestrians aged between 18 and 60, a Pendulum Test Value (PTV) of 36 or above represents an acceptably low risk of slipping when walking in a straight line on a level surface."

SLIP RESISTANCE - MILLIKEN OFFERS

All Milliken LVT products have **DS** class for CE mark, **R10** class for ramp test as a minimum, and **low (≥36) to moderate (≥25)** ratings for wet pendulum test.

Format	Collection	Design	CE Mark	Ramp test	BS 7976 Pendulum test	
			EN 13893	DIN 51130	Dry	Wet
Loose Lay	Original Collection	Eero	DS - Does not slip	R10	55	40
		Heritage Wood	DS - Does not slip	R10	64	41
		Kokutan 5.0	DS - Does not slip	R10	63	39
		Power Grid	DS - Does not slip	R10	51	28
		Polished Concrete	DS - Does not slip	R10	57	28
Flexform Sound™	First Call	On Point	DS - Does not slip	R10	59	32
		Open Shut	DS - Does not slip	R10	60	40
	Change Agent	Earth Science	DS - Does not slip	R11	60	38

Key: probability of slip classification
BS 7976

PTV	Slip potential
0-24	High
25-35	Moderate
≥36	Low

CUSTOMER SERVICE

SERVICE CLIENT / KUNDENSERVICE-CENTER / SERVICIO AL CLIENTE

UK

T. +44 (0)1942 612 777
E. carpetenquiries@milliken.com

FRANCE

T. 08 05 54 27 77
E. demandesmoquettes@milliken.com

DEUTSCHLAND

T. 0800 7243794
E. verkauf@milliken.com

ESPAÑA

T. +44 (0)1942 612 777
E. informaciondemoqueta@milliken.com

SHOWROOMS**LONDON**

T. +44 (0)20 7336 7290

5 Berry Street,
Clerkenwell,
London EC1V 0AA

PARIS

T. +33 (0)1 40 98 06 99

40 Rue Des Mathurins,
75008 Paris

EUROPEAN HEAD OFFICE

SIÈGE EUROP ÉEN / EUROPA ZENTRALE / SEDE CORPORATIVA EUROPA

T. +44 (0)1942 826 073

Beech Hill Plant,
Gidlow Lane,
Wigan WN6 8RN

Cover Image

leonid980. iStock by Getty

www.millikenfloors.com

Milliken™